

# PS (Straight) Series

## Decorative, Vetro Pendant CFL & INC

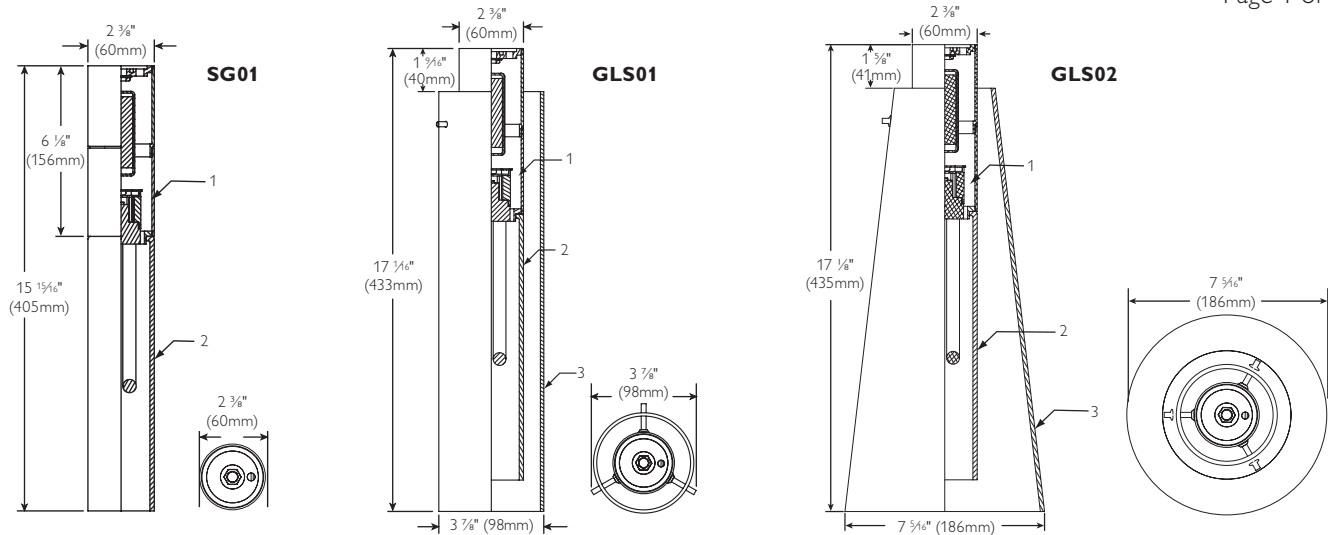

### Ordering Information:

Powerhead	Inner Diffuser	Outer Glass	Suspension Kit	Lamp	Volts
PS13SA	SG01 or SA01	GLS01, GLS01A, or GLS02	*See suspensions below	4-pin elect. Twin Tube 13W	120V
PS132SA				4-pin elect. Twin Tube 13W	277V
PS13QSA				4-pin Quad Tube 13W	120V
PS132QSA				4-pin Quad Tube 13W	277V
PS26SA				4-pin Quad Tube 26W	120V
PS262SA				4-pin Quad Tube 26W	270V
PS50SA*	SG01 only			T-4 Mini-Can 50W	120V

Must order powerhead and glass separately. Suspension Kit must be ordered separately. \*DO NOT USE with acrylic accessories.

### Suspension Kit:

Cat. No	Finish	Description
SK01	Satin aluminum	Clear Metallic Straight Cord/Cable, 120" Length, (10') with canopy
SK02	Satin aluminum	Clear Metallic Straight Cord/Cable, 300" Length, (25') with canopy
ST01	Satin aluminum	36" Length 3/8" Stem with canopy
ST02	Satin aluminum	60" Length 3/8" Stem with canopy
CTC	Satin aluminum	Close to Ceiling Kit with canopy
TM01	Satin aluminum	Silver Track Mounting Kit with Clear Metallic Straight Cord/Cable, 120" Length, (10') (120V only)

### Mounting Options

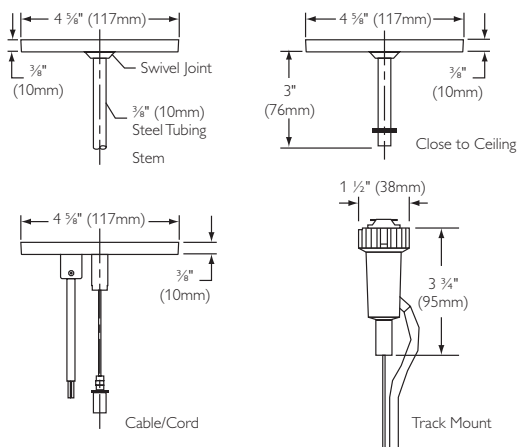

Job Information	Type:
Job Name:	
Cat. No.:	
Notes:	

**PHILIPS**  
**LIGHTOLIER**

# PS (Straight) Series

## Decorative, Vetro Pendant CFL & INC

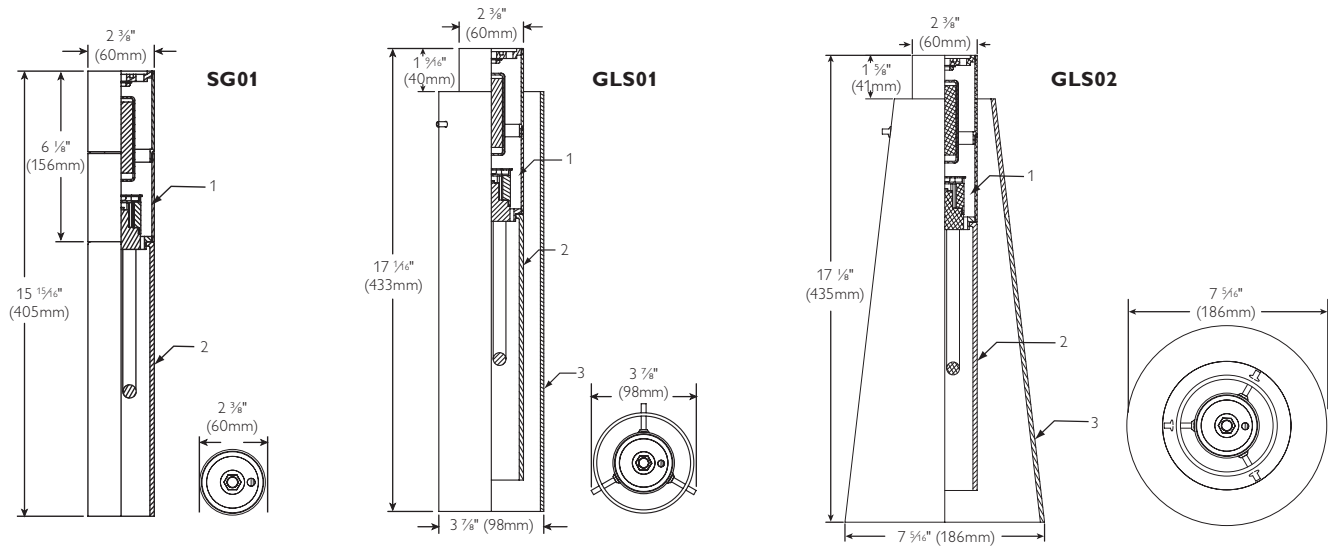

### Features

- 1. Power Compartment:** Die-cast and machined aluminum components. Brushed and clear lacquer finish.
- 2. Primary Diffuser:** (SG01) Triplex hand blown glass or (SA01) opal acrylic.
- 3a. Decorative Glass/Acrylic Assembly:** (GLS01) A straight section of clear extruded glass with polished edges or (GLS01A) a straight section of clear acrylic. All outer assemblies come with a die cast aluminum holder ring with stainless steel support pins.
  - b. Decorative Glass Casing:** A conical section of frosted hand blown glass, die-cast aluminum holder ring and stainless steel support pins.

### Lamping (by others)

**Incandescent:** 50W Max. T-4 Mini Candelabra

**Fluorescent:** 13W 4-Pin Electronic Twin Tube Specify

Lightolier **#56964** (\*\*see chart below)

**\*\*Compact Fluorescent:**

General Electric	Osram/Sylvania	Philips
(1) 13W Twin Tube 4-Pin Compact Fluorescent Lamp		
N/A	CF13DS/E/*	N/A
(1) 13W Quad Tube 4-Pin Compact Fluorescent Lamp		
F13DBX/*/ECO4P	CF13DD/E/*	PL-C13W/*/4P/ALTO

\*Manufacturers color temperature designation

### Electrical - Lampholders

**Incandescent:** E11 Base, porcelain, plated copper alloy screw shell

**Compact Fluorescent:** 13W Twin: 2GX7 Base, high impact thermoset

**Polymer with Brass Contacts.**

**13W Quad:** G24Q-1 Base, high impact thermoset polymer with brass contacts.

### Ballasts:

Flourescent: Electronic	13 Watts TT		13 Watts QT	
	120	277	120	277
Voltage				
Max. Watts	16	11	20	14
Max. Line Current (Amps)	0.136	0.08	0.174	0.114

### Labels

cULus Listed. Suitable for damp locations.

<b>Job Information</b>	<b>Type:</b>
------------------------	--------------

**PHILIPS**  
**LIGHTOLIER**

# PS (Straight) Series

## Decorative, Vetro Pendant CFL & INC

Catalog No. PS13SA w/SG01, 13W 4-Pin Twin Tube, 800 Lumens.

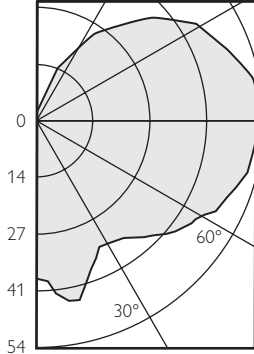

Report No. 3108FR

Candlepower summary			
Angle	Mean CP	Angle	Mean CP
0	39	90	54
5	42	95	54
10	45	100	54
15	43	105	53
20	38	110	51
25	34	115	49
30	34	120	47
35	35	125	44
40	37	130	41
45	40	135	37
50	43	140	33
55	45	145	29
60	47	150	25
65	50	155	20
70	51	160	15
75	53	165	10
80	54	170	5
85	54	175	2
90	54	180	1

Zonal lumen summary	
Zone	Lumens
0-10	4.1
10-20	11.89
20-30	16.15
30-40	22.11
40-50	31.03
50-60	40.41
60-70	49.15
70-80	55.68
80-90	58.92
90-100	58.92
100-110	55.68
110-120	48.66
120-130	39.53
130-140	28.74
140-150	18.32
150-160	9.51
160-170	2.91
170-180	.29

Coefficients of Utilization												
Ceiling	80%				70%		50%		30%			
	70	50	30	10	50	10	50	10	50	10		
Wall	70	50	30	10	50	10	50	10	50	10		
RCR	Zonal Cavity Method - Effective Floor Reflectance = 20%											
Room Cavity Ratio	0	74	74	74	74	69	69	58	58	49	49	36
	1	64	60	56	52	55	48	46	40	37	33	23
	2	57	50	44	40	46	37	38	31	31	25	17
	3	51	43	37	32	39	29	33	24	26	20	13
	4	46	37	31	26	34	24	28	20	23	16	10
	5	42	33	26	22	30	20	25	17	20	14	8
	6	39	29	23	18	27	17	22	14	18	12	7
	7	36	26	20	16	24	15	20	12	16	10	6
	8	33	24	18	14	22	13	18	11	15	9	5
	9	31	22	16	12	20	11	17	9	14	8	4
	10	29	20	14	11	18	10	15	8	13	7	4

Determined in accordance with current IES published procedures  
Luminaire Input Watts = 16.0

Zonal Lumens and Percentages			
Zone	Lumens	%Lamp	%Fixt
0-30	32.14	4	5.8
0-40	54.24	6.8	9.8
0-60	125.68	15.7	22.8
0-90	289.44	36.2	52.4
90-120	163.26	20.4	29.6
90-130	202.8	25.4	36.7
90-150	249.85	31.2	36.7
90-180	262.55	32.8	47.6
0-180	551.99	69	100

\*\* Efficiency = 69% \*\*

Catalog No. PS13QSA w/SG01, 13W 4-Pin Quad Tube, 900 Lumens.

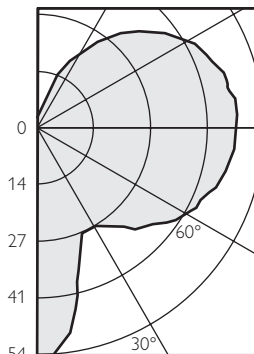

Report No. 3105FR

Candlepower summary			
Angle	Mean CP	Angle	Mean CP
0	54	90	49
5	54	95	49
10	48	100	48
15	43	105	47
20	37	110	46
25	28	115	45
30	28	120	42
35	30	125	40
40	32	130	37
45	35	135	34
50	37	140	30
55	40	145	26
60	42	150	22
65	44	155	18
70	46	160	13
75	47	165	8
80	48	170	4
85	48	175	2
90	49	180	1

Zonal lumen summary	
Zone	Lumens
0-10	4.96
10-20	10.5
20-30	13.06
30-40	18.89
40-50	27.06
50-60	35.81
60-70	43.7
70-80	49.73
80-90	52.51
90-100	53.33
100-110	49.99
110-120	44.19
120-130	35.6
130-140	26.11
140-150	16.58
150-160	8.29
160-170	2.51
170-180	.25

Coefficients of Utilization												
Ceiling	80%				70%		50%		30%			
	70	50	30	10	50	10	50	10	50	10		
Wall	70	50	30	10	50	10	50	10	50	10		
RCR	Zonal Cavity Method - Effective Floor Reflectance = 20%											
Room Cavity Ratio	0	59	59	59	59	55	55	46	46	39	39	28
	1	51	47	44	41	43	38	36	32	30	26	18
	2	45	40	35	31	36	29	30	24	24	20	13
	3	41	34	29	25	31	23	26	19	21	16	10
	4	37	30	24	20	27	19	22	16	18	13	8
	5	34	26	21	17	24	16	20	13	16	11	6
	6	31	23	18	15	21	13	18	11	14	9	5
	7	28	21	16	13	19	12	16	10	13	8	5
	8	26	19	14	11	17	10	14	9	12	7	4
	9	25	17	13	10	16	9	13	8	11	6	4
	10	23	16	11	9	14	8	12	7	10	5	3

Determined in accordance with current IES published procedures  
Luminaire Input Watts = 14.0

Zonal Lumens and Percentages			
Zone	Lumens	%Lamp	%Fixt
0-30	28.52	3.2	5.8
0-40	47.41	5.3	9.6
0-60	110.28	12.3	22.4
0-90	256.23	28.5	52
90-120	147.51	16.4	29.9
90-130	183.11	20.3	37.1
90-150	225.8	25.1	37.1
90-180	236.85	26.3	48
0-180	493.07	54.8	100

\*\* Efficiency = 54.8% \*\*

**Job Information** Type:



# PS (Straight) Series

## Decorative, Vetro Pendant CFL & INC

Catalog No. PS50SA w/SG01, 50W T-4, 950 Lumens.

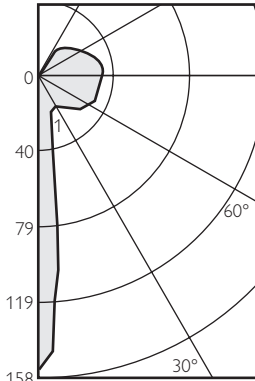

Report No. 3101FR

Candlepower summary			
Angle	Mean CP	Angle	Mean CP
0	158	90	33
5	104	95	34
10	43	100	33
15	23	105	33
20	18	110	32
25	17	115	31
30	19	120	29
35	20	125	27
40	22	130	25
45	24	135	23
50	26	140	21
55	28	145	18
60	29	150	16
65	31	155	13
70	32	160	9
75	33	165	5
80	33	170	1
85	33	175	1
90	33	180	1

Zonal lumen summary	
Zone	Lumens
0-10	8.06
10-20	6.98
20-30	8.18
30-40	12.83
40-50	18.63
50-60	24.81
60-70	30.42
70-80	34.52
80-90	36.01
90-100	36.82
100-110	34.52
110-120	30.42
120-130	24.26
130-140	17.85
140-150	11.61
150-160	5.93
160-170	1.53
170-180	.1

Coefficients of Utilization												
Ceiling	80%				70%		50%		30%			
Wall	70	50	30	10	50	10	50	10	50	10	0	
RCR	Zonal Cavity Method - Effective Floor Reflectance = 20%											
Room Cavity Ratio	0	39	39	39	39	36	36	31	31	26	26	19
	1	34	31	29	27	29	25	24	21	20	18	12
	2	30	26	23	21	24	19	20	16	16	13	9
	3	27	23	19	17	21	15	17	13	14	11	7
	4	25	20	16	14	18	13	15	11	12	9	5
	5	22	18	14	12	16	11	13	9	11	7	5
	6	21	16	12	10	14	9	12	8	10	6	4
	7	19	14	11	9	13	8	11	7	9	6	3
	8	18	13	10	8	12	7	10	6	8	5	3
	9	16	12	9	7	11	6	9	5	7	4	3
	10	15	11	8	6	10	6	8	5	7	4	2

Determined in accordance with current IES published procedures  
Luminaire Input Watts = 50.0

**Zonal Lumens and Percentages**

Zone	Lumens	%Lamp	%Fixt
0-30	23.21	2.4	6.8
0-40	36.04	3.8	10.5
0-60	79.48	8.4	23.1
0-90	180.42	19	52.5
90-120	101.76	10.7	29.6
90-130	126.02	13.3	36.7
90-150	155.48	16.4	36.7
90-180	163.04	17.2	47.5
0-180	343.46	36.2	100

\*\* Efficiency = 36.2% \*\*

Catalog No. PS13SA w/SG01 and GLS01, 13W 4-Pin Twin Tube, 800 Lumens.

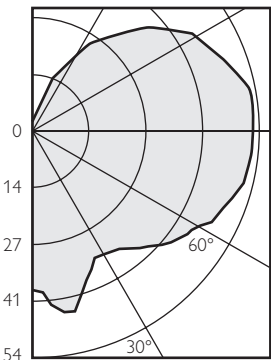

Report No. 3108FR

Candlepower summary			
Angle	Mean CP	Angle	Mean CP
0	39	90	54
5	42	95	54
10	45	100	54
15	43	105	53
20	38	110	51
25	34	115	49
30	34	120	47
35	35	125	44
40	37	130	41
45	40	135	37
50	43	140	33
55	45	145	29
60	47	150	25
65	50	155	20
70	51	160	15
75	53	165	10
80	54	170	5
85	54	175	2
90	54	180	1

Zonal lumen summary	
Zone	Lumens
0-10	4.1
10-20	11.89
20-30	16.15
30-40	22.11
40-50	31.03
50-60	40.41
60-70	49.15
70-80	55.68
80-90	58.92
90-100	58.92
100-110	55.68
110-120	48.66
120-130	39.53
130-140	28.74
140-150	18.32
150-160	9.51
160-170	2.91
170-180	.29

Coefficients of Utilization												
Ceiling	80%				70%		50%		30%			
Wall	70	50	30	10	50	10	50	10	50	10	0	
RCR	Zonal Cavity Method - Effective Floor Reflectance = 20%											
Room Cavity Ratio	0	74	74	74	74	69	69	58	58	49	49	36
	1	64	60	56	52	55	48	46	40	37	33	23
	2	57	50	44	40	46	37	38	31	31	25	17
	3	51	43	37	32	39	29	33	24	26	20	13
	4	46	37	31	26	34	24	28	20	23	16	10
	5	42	33	26	22	30	20	25	17	20	14	8
	6	39	29	23	18	27	17	22	14	18	12	7
	7	36	26	20	16	24	15	20	12	16	10	6
	8	33	24	18	14	22	13	18	11	15	9	5
	9	31	22	16	12	20	11	17	9	14	8	4
	10	29	20	14	11	18	10	15	8	13	7	4

Determined in accordance with current IES published procedures  
Luminaire Input Watts = 16.0

**Zonal Lumens and Percentages**

Zone	Lumens	%Lamp	%Fixt
0-30	32.14	4	5.8
0-40	54.24	6.8	9.8
0-60	125.68	15.7	22.8
0-90	289.44	36.2	52.4
90-120	163.26	20.4	29.6
90-130	202.8	25.4	36.7
90-150	249.85	31.2	36.7
90-180	262.55	32.8	47.6
0-180	551.99	69	100

\*\* Efficiency = 69% \*\*

**Job Information Type:**

**PHILIPS**  
**LIGHTOLIER**

# PS (Straight) Series

## Decorative, Vetro Pendant CFL & INC

Catalog No. PS13QSA w/SG01 and GLS01, 13W 4-Pin Quad Tube, 900 Lumens.

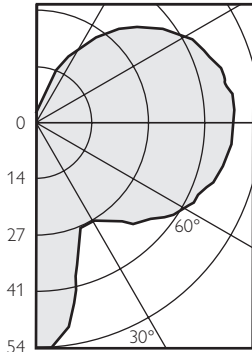

Candlepower summary			
Angle	Mean CP	Angle	Mean CP
0	54	90	49
5	54	95	49
10	48	100	48
15	43	105	47
20	37	110	46
25	28	115	45
30	28	120	42
35	30	125	40
40	32	130	37
45	35	135	34
50	37	140	30
55	40	145	26
60	42	150	22
65	44	155	18
70	46	160	13
75	47	165	8
80	48	170	4
85	48	175	2
90	49	180	1

Zonal lumen summary	
Zone	Lumens
0-10	4.96
10-20	10.5
20-30	13.06
30-40	18.89
40-50	27.06
50-60	35.81
60-70	43.7
70-80	49.73
80-90	52.51
90-100	53.33
100-110	49.99
110-120	44.19
120-130	35.6
130-140	26.11
140-150	16.58
150-160	8.29
160-170	2.51
170-180	.25

Coefficients of Utilization											
Ceiling	80%			70%		50%		30%			
Wall	70	50	30	10	50	10	50	10	50	10	0
RCR	Zonal Cavity Method - Effective Floor Reflectance = 20%										
0	59	59	59	59	55	55	46	46	39	39	28
1	51	47	44	41	43	38	36	32	30	26	18
2	45	40	35	31	36	29	30	24	24	20	13
3	41	34	29	25	31	23	26	19	21	16	10
4	37	30	24	20	27	19	22	16	18	13	8
5	34	26	21	17	24	16	20	13	16	11	6
6	31	23	18	15	21	13	18	11	14	9	5
7	28	21	16	13	19	12	16	10	13	8	5
8	26	19	14	11	17	10	14	9	12	7	4
9	25	17	13	10	16	9	13	8	11	6	4
10	23	16	11	9	14	8	12	7	10	5	3

Determined in accordance with current IES published procedures  
Luminaire Input Watts = 14.0

Zonal Lumens and Percentages			
Zone	Lumens	%Lamp	%Fixt
0-30	28.52	3.2	5.8
0-40	47.41	5.3	9.6
0-60	110.28	12.3	22.4
0-90	256.23	28.5	52
90-120	147.51	16.4	29.9
90-130	183.11	20.3	37.1
90-150	225.8	25.1	37.1
90-180	236.85	26.3	48
0-180	493.07	54.8	100

\*\* Efficiency = 54.8% \*\*

Catalog No. PS50SA w/SG01 and GLS01, 50W T-4, 950 Lumens.

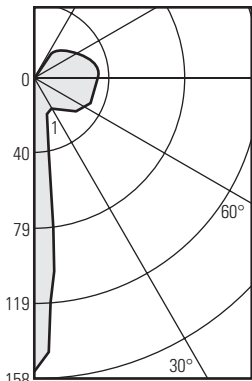

Candlepower summary			
Angle	Mean CP	Angle	Mean CP
0	158	90	33
5	104	95	34
10	43	100	33
15	23	105	33
20	18	110	32
25	17	115	31
30	19	120	29
35	20	125	27
40	22	130	25
45	24	135	23
50	26	140	21
55	28	145	18
60	29	150	16
65	31	155	13
70	32	160	9
75	33	165	5
80	33	170	1
85	33	175	1
90	33	180	1

Zonal lumen summary	
Zone	Lumens
0-10	8.06
10-20	6.98
20-30	8.18
30-40	12.83
40-50	18.63
50-60	24.81
60-70	30.42
70-80	34.52
80-90	36.01
90-100	36.82
100-110	34.52
110-120	30.42
120-130	24.26
130-140	17.85
140-150	11.61
150-160	5.93
160-170	1.53
170-180	.1

Coefficients of Utilization											
Ceiling	80%			70%		50%		30%			
Wall	70	50	30	10	50	10	50	10	50	10	0
RCR	Zonal Cavity Method - Effective Floor Reflectance = 20%										
0	39	39	39	39	36	36	31	31	26	26	19
1	34	31	29	27	29	25	24	21	20	18	12
2	30	26	23	21	24	19	20	16	16	13	9
3	27	23	19	17	21	15	17	13	14	11	7
4	25	20	16	14	18	13	15	11	12	9	5
5	22	18	14	12	16	11	13	9	11	7	5
6	21	16	12	10	14	9	12	8	10	6	4
7	19	14	11	9	13	8	11	7	9	6	3
8	18	13	10	8	12	7	10	6	8	5	3
9	16	12	9	7	11	6	9	5	7	4	3
10	15	11	8	6	10	6	8	5	7	4	2

Determined in accordance with current IES published procedures  
Luminaire Input Watts = 50

Zonal Lumens and Percentages			
Zone	Lumens	%Lamp	%Fixt
0-30	23.21	2.4	6.8
0-40	36.04	3.8	10.5
0-60	79.48	8.4	23.1
0-90	180.42	19	52.5
90-120	101.76	10.7	29.6
90-130	126.02	13.3	36.7
90-150	155.48	16.4	36.7
90-180	163.04	17.2	47.5
0-180	343.46	36.2	100

\*\* Efficiency = 36.2% \*\*

**Job Information Type:**

**PHILIPS**  
**LIGHTOLIER**

# PS (Straight) Series

## Decorative, Vetro Pendant CFL & INC

Catalog No. PS13SA w/SG01 and GLS 02, 4-Pin Twin Tube, 800 Lumens.

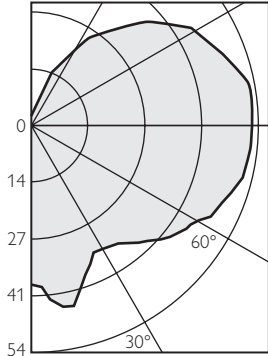

Report No. 3108FR

Candlepower summary			
Angle	Mean CP	Angle	Mean CP
0	39	90	54
5	42	95	54
10	45	100	54
15	43	105	53
20	38	110	51
25	34	115	49
30	34	120	47
35	35	125	44
40	37	130	41
45	40	135	37
50	43	140	33
55	45	145	29
60	47	150	25
65	50	155	20
70	51	160	15
75	53	165	10
80	54	170	5
85	54	175	2
90	54	180	1

Zonal lumen summary	
Zone	Lumens
0-10	4.1
10-20	11.89
20-30	16.15
30-40	22.11
40-50	31.03
50-60	40.41
60-70	49.15
70-80	55.68
80-90	58.92
90-100	58.92
100-110	55.68
110-120	48.66
120-130	39.53
130-140	28.74
140-150	18.32
150-160	9.51
160-170	2.91
170-180	.29

Coefficients of Utilization											
Ceiling	80%			70%		50%		30%		0	
Wall	70	50	30	10	50	10	50	10	50	10	
RCR	Zonal Cavity Method - Effective Floor Reflectance = 20%										
0	74	74	74	74	69	69	58	58	49	49	36
1	64	60	56	52	55	48	46	40	37	33	23
2	57	50	44	40	46	37	38	31	31	25	17
3	51	43	37	32	39	29	33	24	26	20	13
4	46	37	31	26	34	24	28	20	23	16	10
5	42	33	26	22	30	20	25	17	20	14	8
6	39	29	23	18	27	17	22	14	18	12	7
7	36	26	20	16	24	15	20	12	16	10	6
8	33	24	18	14	22	13	18	11	15	9	5
9	31	22	16	12	20	11	17	9	14	8	4
10	29	20	14	11	18	10	15	8	13	7	4

Determined in accordance with current IES published procedures  
Luminaire Input Watts = 16

Zonal Lumens and Percentages			
Zone	Lumens	%Lamp	%Fixt
0-30	32.14	4	5.8
0-40	54.24	6.8	9.8
0-60	125.68	15.7	22.8
0-90	289.44	36.2	52.4
90-120	163.26	20.4	29.6
90-130	202.8	25.4	36.7
90-150	249.85	31.2	36.7
90-180	262.55	32.8	47.6
0-180	551.99	69	100

\*\* Efficiency = 69% \*\*

Catalog No. PS13QSA w/SG01 and GLS02, 13W 4-Pin Quad Tube, 900 Lumens.

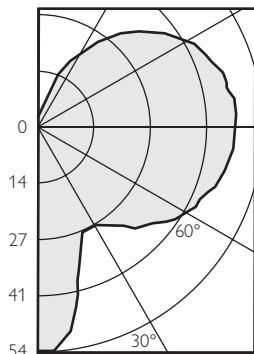

Report No. 3105FR

Candlepower summary			
Angle	Mean CP	Angle	Mean CP
0	54	90	49
5	54	95	49
10	48	100	48
15	43	105	47
20	37	110	46
25	28	115	45
30	28	120	42
35	30	125	40
40	32	130	37
45	35	135	34
50	37	140	30
55	40	145	26
60	42	150	22
65	44	155	18
70	46	160	13
75	47	165	8
80	48	170	4
85	48	175	2
90	49	180	1

Zonal lumen summary	
Zone	Lumens
0-10	4.96
10-20	10.5
20-30	13.06
30-40	18.89
40-50	27.06
50-60	35.81
60-70	43.7
70-80	49.73
80-90	52.51
90-100	53.33
100-110	49.99
110-120	44.19
120-130	35.6
130-140	26.11
140-150	16.58
150-160	8.29
160-170	2.51
170-180	.25

Coefficients of Utilization											
Ceiling	80%			70%		50%		30%		0	
Wall	70	50	30	10	50	10	50	10	50	10	
RCR	Zonal Cavity Method - Effective Floor Reflectance = 20%										
0	59	59	59	59	55	55	46	46	39	39	28
1	51	47	44	41	43	38	36	32	30	26	18
2	45	40	35	31	36	29	30	24	24	20	13
3	41	34	29	25	31	23	26	19	21	16	10
4	37	30	24	20	27	19	22	16	18	13	8
5	34	26	21	17	24	16	20	13	16	11	6
6	31	23	18	15	21	13	18	11	14	9	5
7	28	21	16	13	19	12	16	10	13	8	5
8	26	19	14	11	17	10	14	9	12	7	4
9	25	17	13	10	16	9	13	8	11	6	4
10	23	16	11	9	14	8	12	7	10	5	3

Determined in accordance with current IES published procedures  
Luminaire Input Watts = 14

Zonal Lumens and Percentages			
Zone	Lumens	%Lamp	%Fixt
0-30	28.52	3.2	5.8
0-40	47.41	5.3	9.6
0-60	110.28	12.3	22.4
0-90	256.23	28.5	52
90-120	147.51	16.4	29.9
90-130	183.11	20.3	37.1
90-150	225.8	25.1	37.1
90-180	236.85	26.3	48
0-180	493.07	54.8	100

\*\* Efficiency = 54.8% \*\*

**Job Information** Type:

**PHILIPS**  
**LIGHTOLIER**

# PS (Straight) Series

## Decorative, Vetro Pendant CFL & INC

Catalog No. PS50SA w/SG01 and GLS02, 50W T-4, 950 Lumens.

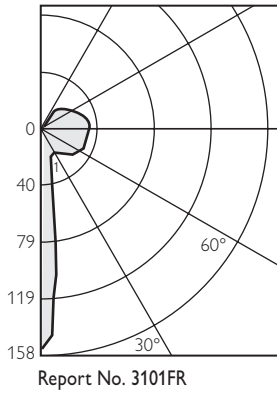

Candlepower summary			
Angle	Mean CP	Angle	Mean CP
0	158	90	33
5	104	95	34
10	43	100	33
15	23	105	33
20	18	110	32
25	17	115	31
30	19	120	29
35	20	125	27
40	22	130	25
45	24	135	23
50	26	140	21
55	28	145	18
60	29	150	16
65	31	155	13
70	32	160	9
75	33	165	5
80	33	170	1
85	33	175	1
90	33	180	1

Zonal lumen summary	
Zone	Lumens
0-10	8.06
10-20	6.98
20-30	8.18
30-40	12.83
40-50	18.63
50-60	24.81
60-70	30.42
70-80	34.52
80-90	36.01
90-100	36.82
100-110	34.52
110-120	30.42
120-130	24.26
130-140	17.85
140-150	11.61
150-160	5.93
160-170	1.53
170-180	.1

Coefficients of Utilization											
Room Cavity Ratio	80%		70%		50%		30%				
RCR	Zonal	Cavity	Method	- Effective	Floor	Reflectance	= 20%				
0	39	39	39	39	36	36	31	31	26	26	19
1	34	31	29	27	29	25	24	21	20	18	12
2	30	26	23	21	24	19	20	16	16	13	9
3	27	23	19	17	21	15	17	13	14	11	7
4	25	20	16	14	18	13	15	11	12	9	5
5	22	18	14	12	16	11	13	9	11	7	5
6	21	16	12	10	14	9	12	8	10	6	4
7	19	14	11	9	13	8	11	7	9	6	3
8	18	13	10	8	12	7	10	6	8	5	3
9	16	12	9	7	11	6	9	5	7	4	3
10	15	11	8	6	10	6	8	5	7	4	2

Determined in accordance with current IES published procedures  
Luminaire Input Watts = 50

Zonal Lumens and Percentages			
Zone	Lumens	%Lamp	%Fixt
0-30	23.21	2.4	6.8
0-40	36.04	3.8	10.5
0-60	79.48	8.4	23.1
0-90	180.42	19	52.5
90-120	101.76	10.7	29.6
90-130	126.02	13.3	36.7
90-150	155.48	16.4	36.7
90-180	163.04	17.2	47.5
0-180	343.46	36.2	100

\*\* Efficiency = 36.2% \*\*



Philips Lightolier  
e: lol.webmaster@philips.com  
t: (508) 679-8131  
w: www.lightolier.com

PS-CFL-INC-S May 31, 2011

Specifications are subject to change without notice.  
© Koninklijke Philips Electronics N.V., 2011. All rights reserved.

**Job Information Type:**