

DX2 Series

DIE-CAST ALUMINUM LED EXIT

Page 1 of 2

DX21RCANSD2T

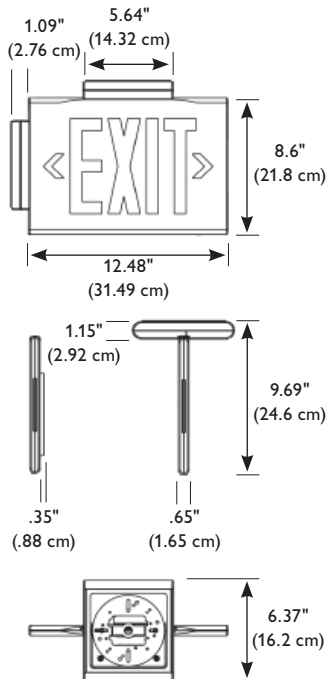

Features

Illumination: Illumination is accomplished with high-output Light Emitting Diodes. Proprietary internal molded-acrylic panel (thickness: 0.45") for even illumination.

Housing: Die cast aluminum construction with NFPA compliant, field-selectable chevrons. Available in brushed aluminum, white, and black. For surface ceiling and end mounting applications a canopy, which utilizes a quick connect locking system for secure installations, is provided. Also available in a wall mount version for direct surface mounting.

Battery: Maintenance free, sealed nickel metal hydride battery with 10 year life. NiMH battery is a non-toxic, environmentally friendly product which is recyclable.

Electronics: 120/277

VAC dual voltage input. Microprocessor controlled charge, transfer and monitoring system. Charging system is complete with low voltage disconnect, AC lockout, and brownout protection. Self-powered units include an AC indicator/systems status lamp and manual test switch.

Self-Testing Diagnostics

(standard): Standard on self-powered models, self-testing mode automatically runs a one minute test every 30 days and a 30 minute test every 180 days. A one minute or 90 minute test may be initiated via the push to test switch on the unit or by activating the appropriate test command on the SDREMOTE test device accessory.

Electrical Specifications:

AC Only Red:
1.70 W (120 VAC)
1.72 W (277 VAC)
AC Only Green:
2.69 W (120 VAC)
2.72 W (277 VAC)
Emergency Operation Red:
2.66 W (120 VAC)
2.72 W (277 VAC)
Emergency Operation Green:
4.09 W (120 VAC)
4.14 W (277 VAC)

Code Compliance

UL 924 listed. NFPA 101 illumination standards.

Warranty

Three year full electronics warranty. Five year full plus five year prorated battery warranty.

Job Information Type:

Job Name:

Cat. No.:

Notes:

PHILIPS

LIGHTOLIER

DX2 Series

DIE-CAST ALUMINUM LED EXIT

Page 2 of 2

Ordering Information

DX2							
Series	Number of Faces	Letter Color	Mounting	Housing Color	Battery	Model Designator	Factory Installed Options
DX2 = Die Cast LED Exit	1 = Single 2 = Double	R = Red G = Green	C = Ceiling/End W = Wall ¹	A = Brushed Aluminum W = White B = Black	Blank = AC Only N = NiMH	Blank = AC Only Models SD2T = Self-Diagnostic/ Self-Testing ²	A = Audible Self-Testing Diagnostics ² BF = Buzzer/Flasher ² BZ = Buzzer ² DC = 12-48 VDC Remote Emergency Input ³ DL = Damp Location Listing EX = Custom Voltage/Frequency (consult factory) FA = Fire Alarm Activated Flasher ³ FL = Emergency Mode Flasher ² 2CKT1 = 120 VAC Two Circuit 2CKT2 = 277 VAC Two Circuit

Accessories (order as a separate item)
SDREMOTE = Infrared Remote Test Device

Note
1. Single face signs only.
2. NiMH units only.
3. AC only units.



Philips Lightolier
e: lol.webmaster@philips.com
t: (508) 679-8131
w: www.lightolier.com

DX2 Series September 19, 2011

Specifications are subject to change without notice.
© Koninklijke Philips Electronics N.V., 2011. All rights reserved.

Job Information Type: