

Architectural Decorative Vetro Downlight DA14

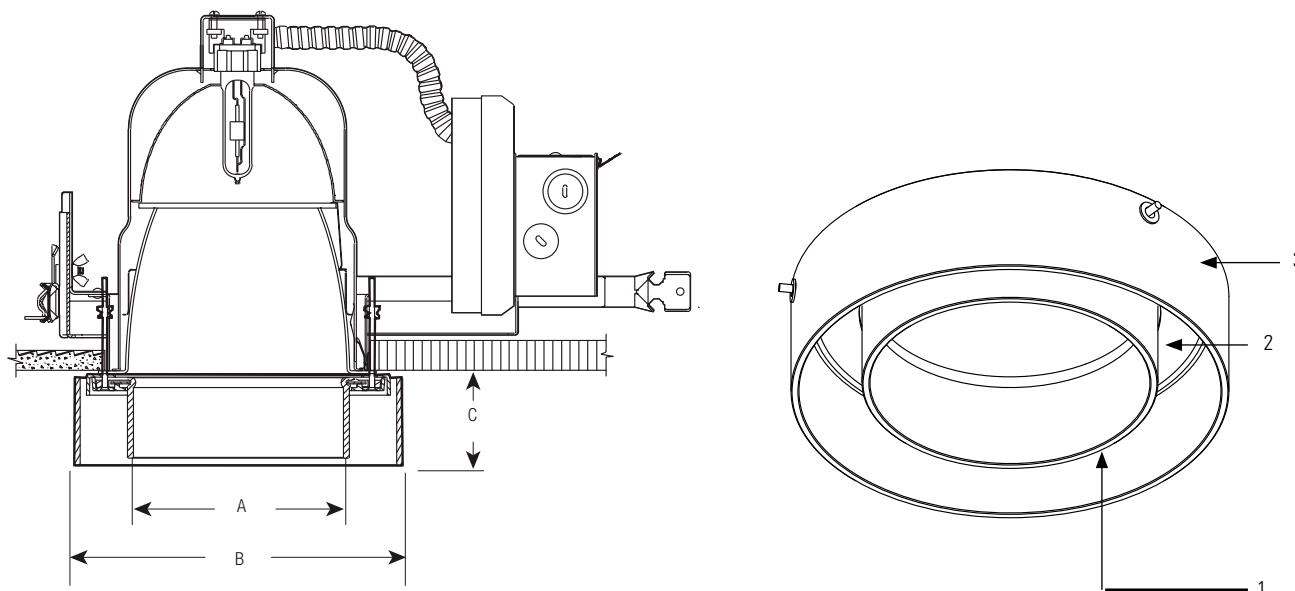

Complete Fixture consists of Decorative Element, Trim-Kit + Frame-In Kit. Each sold separately.

3 Piece Ordering System, Example: D4A14 + C4T4VWCL + C420T4E1

Aperture	Decorative Element Catalog No.	Trim- Kit	Frame-In Kit	Lamping	Dimensions		
					A	B	C
4"	D4A14	C4T4HWCL C4T4VWCL C4T4VNCL C4T4VMCL	C420T4E1, C420T4E2 C439T4E1, C439T4E2	(1) 20W T4 (1) 39W T4	4 1/8"	7 1/4"	2 1/4"
6"	D6A14	C6T6VWCL C6T6VNCL C6T6VMCL	C639T6E1, C639T6E2,	(1) 39W T6	5 1/2"	8 5/8"	2 3/8"

Features

- Decorative Element:** Solid high temp, UV resistant composite with open aperture; frosted interior diameter, polished exterior and machined facet along bottom edge.
- Die Cast Construction Ring:** Exterior edge of construction ring is visible, satin aluminum finish matches diameter of decorative element for a flangeless appearance.
- Fastener cover:** Stamped aluminum cover ring provided on top of decorative element to cover fasteners and prevent visibility through clear decorative element.
- Mounting Frame Fasteners:** Four #8-32 screws and 4 knurled die-cast thumb screws secure construction ring to frame in kit.
- Reflector:** FLANGELESS TRIM REQUIRED. Specified separately. Use Specular Clear (CL) finish for best performance and aesthetics
- Frame-In Kit:** Specified separately. See Trim Specification Sheet for additional details.

Mechanical

Die cast construction ring securely fastened to four #8-32 screws and 4 knurled die-cast thumb screws. Decorative Element quarter turn twist and lock into die cast construction ring.

Labels

U.L. (Damp Location)

Job Information	Type:
Job Name:	
Cat. No.:	
Lamp(s):	
Notes:	