

Architectural Decorative Vetro Downlight **DA14**

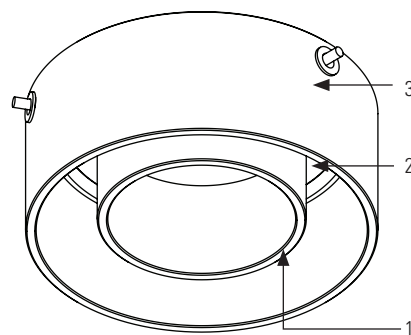
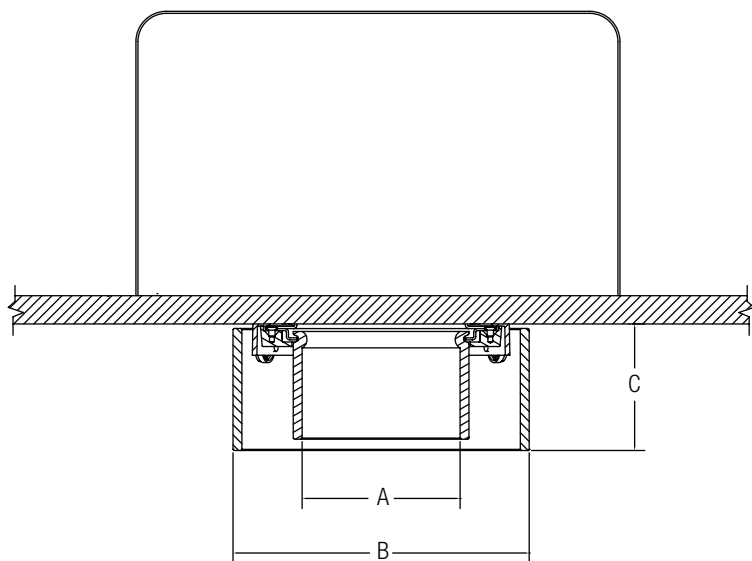

Complete fixture consists of Decorative Element/Trim-Kit + Frame-In Kit. Each sold separately.
2 Piece Ordering System, Example: D3MR14+ C3LV

Decorative Element/Trim Kit Catalog No.		Frame-In Kit	Lamping	Dimensions		
				A	B	C
3" Evolution	D3MR14	C3LV, C3AICLV, C3ALV, C3LVE1, C3LVE2, C3ALVE1, C3AICLVE1, C3ALVE2	50W MR16	2 3/4"	5 1/4"	2 1/4"
4" Evolution	D4MR14	C4LV; C4ALV; C4AICLV	50W MR16	4"	6 3/4"	2 1/2"

Features

- Decorative Element:** Solid high temp, UV resistant composite with open aperture; frosted interior diameter, polished exterior and machined facet along bottom edge.
- Die Cast Construction Ring:** Exterior edge of construction ring is visible, satin aluminum finish matches diameter of decorative element for a flangeless appearance.
- Integral Reflector:** 16 ga. aluminum, 50° visual cutoff to lamp and lamp image. Decorative Element is mechanically attached to reflector via die cast ring. Reflector is specular clear for best performance and aesthetics.
- Cover Glass:** 3" Evolution contains high temperature soft focus lens. 4" Evolution contains high temperature perimeter frost.
- Trim Kit:** For 3" and 4" Evolution, trim kit, reflector and decorative element ship complete.
- Frame-In Kit:** Specified separately. See Trim Kit Specification Sheet for details.

Mechanical

Decorative element is mechanically secured to the die cast construction ring and the integral reflector from the factory.

Labels

U.L. (Damp Location)

Job Information	Type:
Job Name:	
Cat. No.:	
Lamp(s):	
Notes:	