

Architectural Decorative, Vetro, 4", 6" & 7" CFL

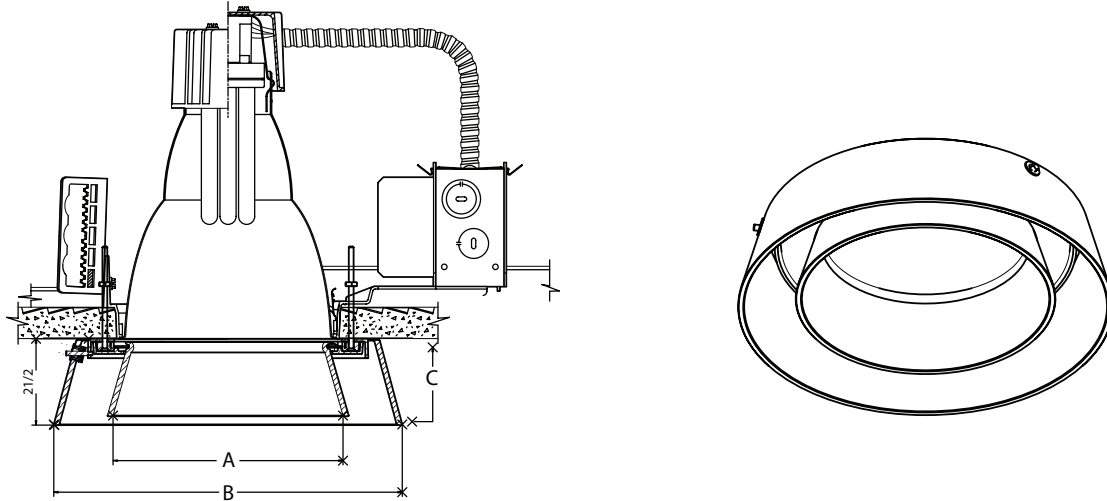

Decorative Element Catalog No.	Trim- Kit	Frame-In Kit	Lamping	Dimensions		
				A	B	C
D4A13	8011CL	4118VU Family D4132VU Family	(1) 18W Triple Tube (1) 26W, 32W or 42W Triple Tube	5 1/8"	8 1/2"	2 1/4"
D6A13	8021CL; 8031CL; 8091DCL 8052CL 8051CL	S6132BU Family 6213HU Family 6218HU Family	(1) 26W or 32W Triple Tube (2) 13W Quad (2) 18W Quad	6 5/8"	10"	2 1/2"
D7A13	8022CL; 8037CL; 8097DCL 8056CL; 8096DCL 8056CL; 8096DCL 8065CL	S7142BU Family 7218HU Family S7226HU Family 7126HU Family	(1) 26W, 32W or 42W Triple Tube (2) 18W Quad Tube (2) 26W Quad Tube (1) 26W Quad Tube	8 1/8"	11 1/2"	2 1/2"

Features

- Decorative element:** Inner: angled hand blown triplex glass carefully proportioned to each aperture size. Glass is gently and evenly illuminated for clean brightness recognition. Outer: angled hand down clear glass.
- Die cast finish ring:** Aluminum Die Cast finish ring with crisp 90 degree edges conceals all fasteners for a clean finished appearance.
- Die cast construction ring:** Internal die cast construction ring is mechanically attached to frame in kit and is concealed by finish ring.
- Mounting frame fasteners:** Four #8-32 screws and 4 knurled die-cast thumb screws secure construction ring to frame in kit.
- Reflector:** Flangeless trim required. Specified separately. Use specular clear (CL) finish for best performance and aesthetics.
- Frame-In Kit:** Specified separately. See trim kit specification sheet for additional details.

Mechanical

Decorative element is mechanically secured to the die cast construction ring and the integral reflector from the factory.

Labels

cULus (Damp Location)

Job Information	Type:
Job Name:	
Cat. No.:	
Notes:	