

Decorative, Vetro, 4" & 6" Metal Halide

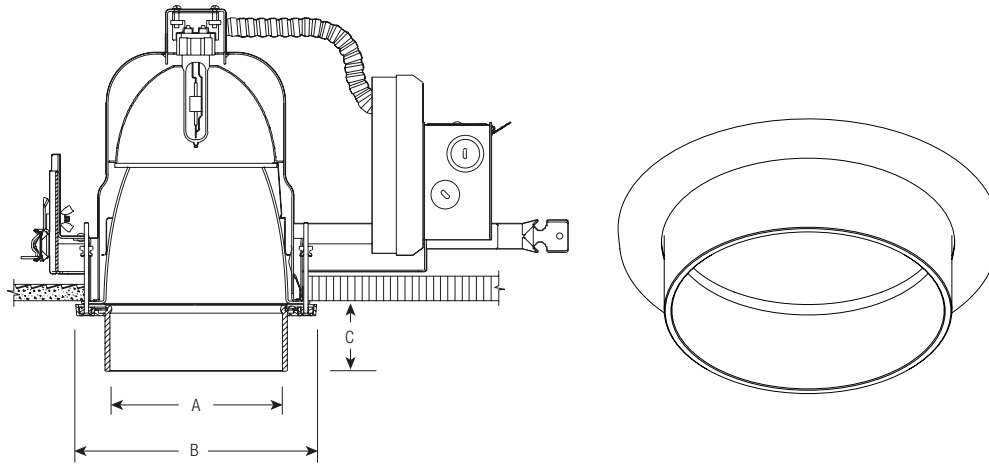

Complete Fixture consists of Decorative Element, Trim-Kit + Frame-In Kit. Each sold separately.

3 Piece Ordering System, Example: D4A04 + C4T4VWCL + C420T4E1

| Aperture | Decorative Element Catalog No. | Trim- Kit | Frame-In Kit | Lamping | Dimensions | | |
|----------|--------------------------------|--|--|--------------------------|------------|--------|--------|
| | | | | | A | B | C |
| 4" | D4A04 | C4T4HWCL C4T4VWCL C4T4VNCL C4T4VMCL | C420T4E1, C420T4E2 C439T4E1, C439T4E2 | (1) 20W T4 (1) 39W T4 | 4 1/8" | 6 1/4" | 2" |
| 6" | D6A04 | C6T6VWCL C6T6VNCL C6T6VMCL | C639T6E1, C639T6E2 | (1) 39W T6 | 5 1/2" | 7 3/4" | 2 1/8" |

Features

- Decorative element:** Cylindrical hand blown triplex glass carefully proportioned to each aperture size. Glass is gently and evenly illuminated for clean brightness recognition.
- Die cast finish ring:** Aluminum die cast finish ring with crisp 90 degree edges conceals all fasteners for a clean finished appearance.
- Die cast construction ring:** Internal die cast construction ring is mechanically attached to frame in kit and is concealed by finish ring.
- Mounting frame fasteners:** Four #8-32 screws and 4 knurled die-cast thumb screws secure construction ring to frame in kit.
- Reflector:** Flangeless trim required. Specified separately. Use specular clear (CL) finish for best performance and aesthetics.
- Frame-In Kit:** Specified separately. See Trim specification sheet for additional details.

Mechanical

Die cast construction ring securely fastened to four mounting frame studs and 4 (3/8" dia.) aluminum knobs. Decorative Element and finish ring quarter turn twist and lock into die cast construction ring.

Labels

U.L. (Damp Location)

| Job Information | Type: |
|-----------------|-------|
| Job Name: | |
| Cat. No.: | |
| Notes: | |