

# D7A03

## Decorative, Vetro, 7" LED

Page 1 of 1

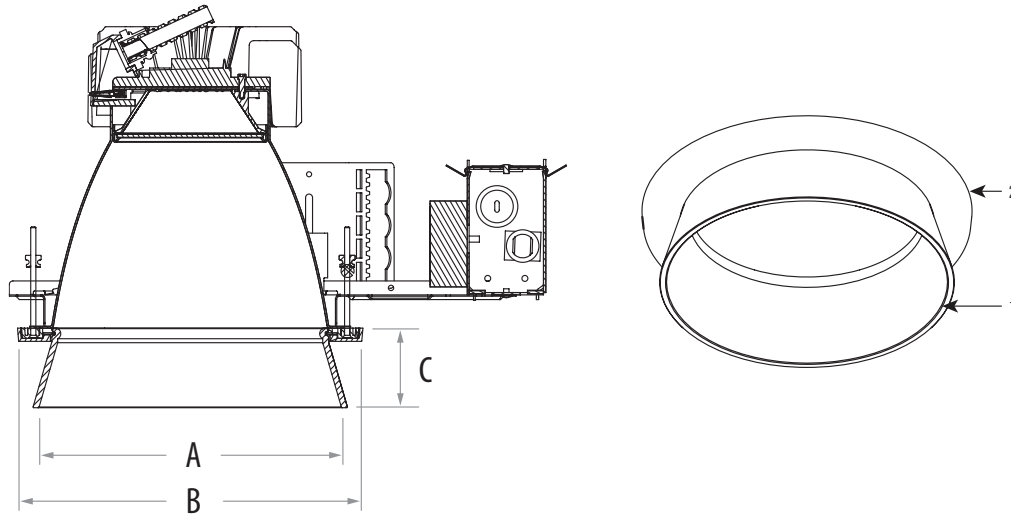

**3 Piece Ordering System:** Complete Fixture consists of Decorative Element, Calculate Light Engine, and Calculate Frame-In Kit. Each sold separately.

Aperture	Decorative Element Catalog No.	Flangeless Trim	Frame-In Kit	Wattage	Dimensions		
					A	B	C
7"	D7A03	C7L1520 Series	C7L15N Series	27W	8 1/8"	9 1/4"	2 1/8"
			C7L20N Series	39W			

### Features

- Decorative element:** Angled hand blown triplex glass carefully proportioned to each aperture size. Glass is gently and evenly illuminated for clean brightness recognition.
- Die cast finish ring:** Aluminum die cast finish ring with crisp 90 degree edges conceals all fasteners for a clean finished appearance.
- Die cast construction ring:** Internal die cast construction ring is mechanically attached to frame in kit and is concealed by finish ring.
- Mounting Frame Fasteners:** Four #8-32 screws and 4 knurled die-cast thumb screws secure construction ring to frame in kit.
- Reflector:** Flangeless trim required. Specified separately. Use Specular Clear (CL) finish for best performance and aesthetics.
- Frame-In Kit:** Specified separately. See trim specification sheet for additional details.

### Mechanical

Die cast construction ring securely fastened to four mounting frame studs and 4 (3/8" dia.) aluminum knobs. Decorative Element and finish ring quarter turn twist and lock into die cast construction ring.

### Labels

U.L. (Damp Location)

Job Information	Type:
Job Name:	
Cat. No.:	
Notes:	

**PHILIPS**  
**LIGHTOLIER**