

D6A03

Decorative, Vetro, 6" LED

Page 1 of 1

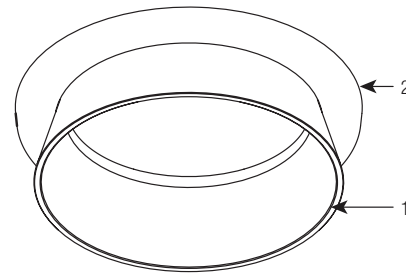
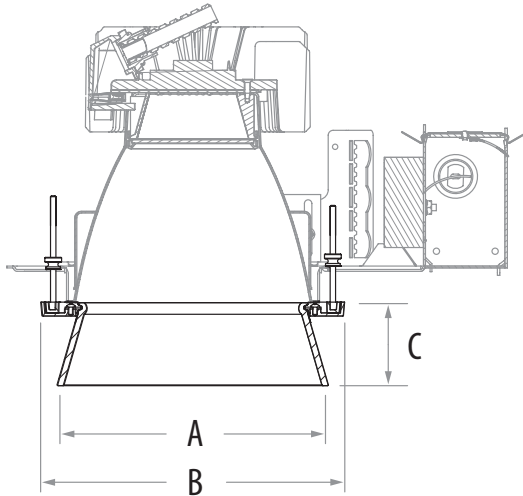

3 Piece Ordering System: Complete Fixture consists of Decorative Element, Calculite Light Engine, and Calculite Frame-In Kit. Each sold separately.

Aperture	Decorative Element Catalog No.	Flangeless Trim	Frame-In Kit	Wattage	Dimensions		
					A	B	C
6"	D6A03	C6L1520 Series	C6L15N Series	27W	6 5/8"	7 3/4"	2 1/8"
			C6L20N Series	39W			

Features

- Decorative element:** Angled hand blown triplex glass carefully proportioned to each aperture size. Glass is gently and evenly illuminated for clean brightness recognition.
- Die cast finish ring:** Aluminum die cast finish ring with crisp 90 degree edges conceals all fasteners for a clean finished appearance.
- Die cast construction ring:** Internal die cast construction ring is mechanically attached to frame in kit and is concealed by finish ring.
- Mounting frame fasteners:** Four #8-32 screws and 4 knurled die-cast thumb screws secure construction ring to frame in kit.
- Reflector:** Flangeless trim required. Specified separately. Use specular clear (CL) finish for best performance and aesthetics.
- Frame-in kit:** Specified separately. See trim specification sheet for additional details.

Mechanical

Die cast construction ring securely fastened to four mounting frame studs and 4 (3/8" dia.) aluminum knobs. Decorative Element and finish ring quarter turn twist and lock into die cast construction ring.

Labels

U.L. (Damp Location)

Job Information	Type:
Job Name:	
Cat. No.:	
Notes:	

PHILIPS
LIGHTOLIER