

Architectural Decorative, Vetro, 4" LED

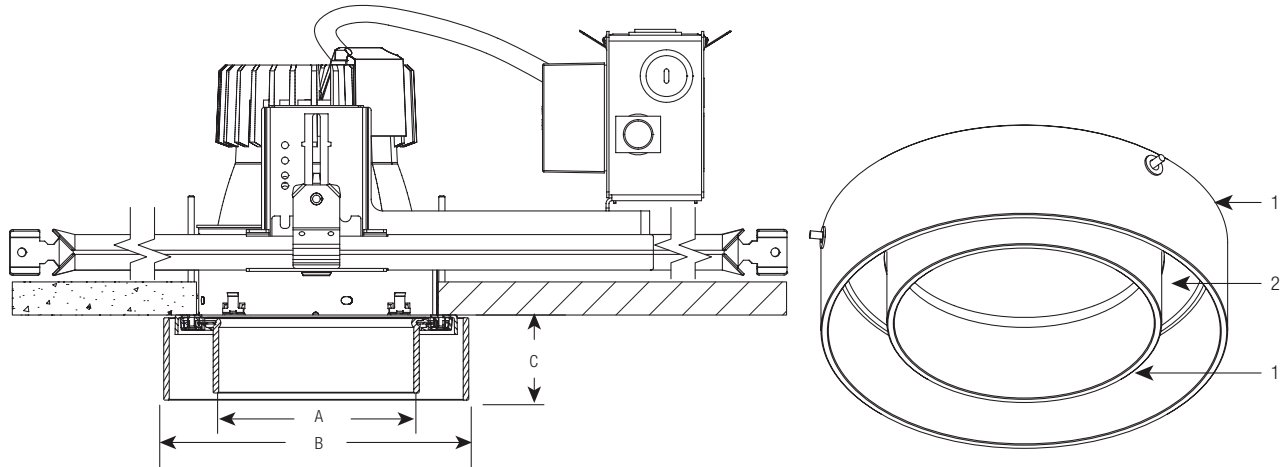

3 Piece Ordering System: Complete Fixture consists of Decorative Element, Calculite Light Engine, and Calculite Frame-In Kit. Each sold separately.

Aperture	Decorative Element Catalog No.	Frame-In Kit and Trim	Wattage	Dimensions		
				A	B	C
4"	D4A14	C4L05 Series	10W	4 1/8"	7 1/4"	2 1/4"
		C4L10 Series	20W			

Features

- Decorative element:** Inner: Cylindrical hand blown triplex glass carefully proportioned to each aperture size. Glass is gently and evenly illuminated for clean brightness recognition. Outer: cylindrical hand blown clear glass.
- Die cast finish ring:** Aluminum Die Cast finish ring with crisp 90 degree edges conceals all fasteners for a clean finished appearance.
- Die cast construction ring:** Internal die cast construction ring is mechanically attached to frame in kit and is concealed by finish ring.
- Mounting frame fasteners:** Four #8-32 screws and 4 knurled die-cast thumb screws secure construction ring to frame in kit.
- Reflector:** Flangeless trim required. Specified separately. Use specular clear (CL) finish for best performance and aesthetics.
- Frame-In Kit:** Specified separately. See trim kit specification sheet for additional details.

Mechanical

Die cast construction ring securely fastened to four #8-32 screws and 4 knurled die-cast thumb screws. Decorative Element quarter turn twist and lock into die cast construction ring.

Labels

cULus (Wet Location)

Job Information	Type:
Job Name:	
Cat. No.:	
Notes:	